



OpenWave: U.S.-Brazil 100G Experimental Alien Wave



**13th Annual ON*VECTOR Photonics Workshop
March 5-6, 2014
CallIT2, UCSD**

**Julio Ibarra, FIU, PI
Heidi Alvarez, FIU, Co-PI
Chip Cox, FIU, Co-PI
Louis Fox, CENIC, Co-PI**



OpenWave 100G project



- OpenWave is a project (award# 1341895) under NSF IRNC ProNet AmLight award for U.S.-Latin America connectivity
- OpenWave will deploy an experimental 100G alien wave between the U.S. and Brazil
- OpenWave is an experiment consisting of 2 major goals:
 - Understand how to deploy a 100G trans-oceanic alien wave on a highly constrained operational undersea cable system
 - Understand how to operate a 100G alien wave with a total span of approximately 10,000km
- Broader Impacts:
 - Impact is the potential of introducing a novel approach for upgrading production undersea optical fiber systems
 - Facilitating academic access to submarine spectrum
 - Brings a new resource to science and education, preparing for future science demands, such as the Large Synoptic Survey Telescope (LSST), which is expected to push to the limits of 100Gb/s network connections, bridging the southern and northern hemispheres.



OpenWave Project Partners



- NSF and the IRNC program
- Florida International University via the AmLight Project
- Brazil via the ANSP and RNP
- PadTec, optical equipment manufacturer in Brazil
- Latin American Nautilus, submarine cable system operator
- Florida LambdaRail (FLR)
- Internet2

OpenWave Challenges

- 100G alien wave technology has not been field tested in this type of environment
- Complexity of LAN's undersea cable system
 - Real-world submarine cable system that is 14+ years old with many amplifiers
 - Complex overlays using multiple digital modulation schemes
 - 10G waves with Non-return-to-zero (NRZ) modulation at 100GHz, 50GHz and 33GHz spacing
 - 40G & 100G waves in an overlay using BP & QPSK modulation at 50GHz spacing
 - Overcoming non-linear phase noise effects
 - Optical Signal to Noise Ratio (OSNR), Bit Error Rate (BER), Chromatic Dispersion, etc.

OpenWave and AmLight Topology

- 4 100G segments (future):
 - St. Croix (STX)-Fortaleza 4,200km
 - Fortaleza-Rio, 3,500km
 - Rio-Santos, 400km
 - Miami-STX, 2,400km
- ANSP: 2x 10G links S Paulo – Miami
 - (W) via Santiago (LAN)
 - (E) direct (Telefonica)
- RNP: 2x 10G links S Paulo – Miami
 - (W) direct (Telefonica)
 - (E) via Rio de Janeiro & Fortaleza (LAN)
 - (+ redundant terrestrial links)



OpenWave System Characteristics

- Four spans in the path; longest measured at 4,200km
- 100G Alien Wave will be deployed using Padtec's devices with LAN's hybrid Ciena SLTE and Alcatel repeatered line
 - New Alien Wave deployment in SAC cable
 - Differential Quadrature Phase Shift Keying (DQPSK)
 - Coherent Detection technology
- Use of a 50GHz channel, plus some guard channels of 50Ghz
 - Number of guard channels depends on results of simulation and lab tests
 - Prevents Non Linear Effects on production waves

Methodology

- Separate the Miami – São Paulo path into 4 spans:
 - a. Miami to St. Croix (2,400km)
 - b. St. Croix to Fortaleza/BR (4,200km)
 - c. Fortaleza to Rio de Janeiro (3,500km)
 - d. Rio de Janeiro to Santos (400km)
- Modeling span (b): (approx. 30 days)
 - (b) is the longest span
- Simulation of (b): (approx. 30-45 days)
- Laboratory tests of (b): (approx. 30 days)
- Repeat for (a), (c), (d) and (e) – (up to 15 days each)
- Evaluation of the results by all partners
- Deploy the 100G in the SAC cable

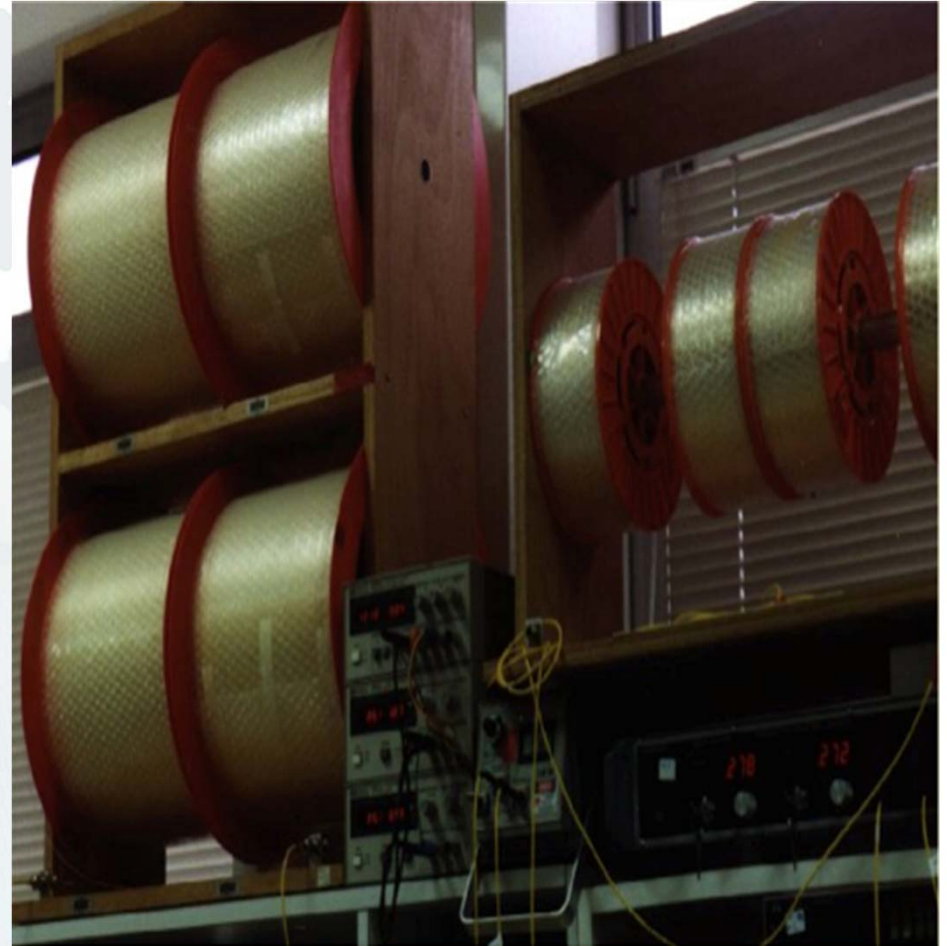

OpenWave Network Design

OpenWave & 100G AtlanticWave - 2014

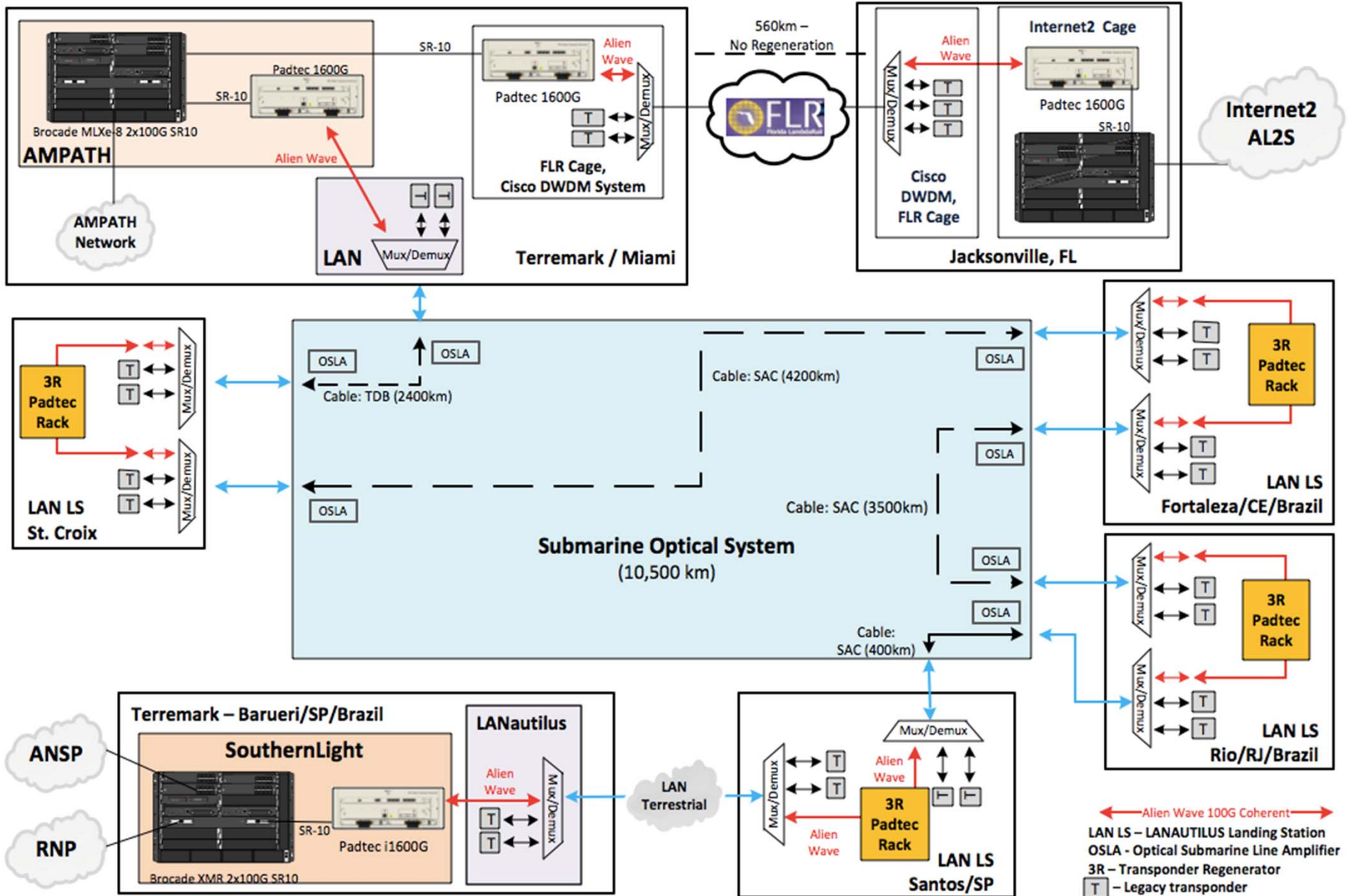

Critical Success Factors

- Overcoming non-linear phase noise effects
 - Bit Error Rate (BER)
 - Sensitivity to Optical Signal-to-Noise Ratio (OSNR)
 - Chromatic Dispersion
- Q-value performance margin
 - How well the wave is performing in relation to BER and OSNR
 - Must account for aging and faults on the fiber
- St. Croix – Fortaleza span is most challenging
 - 4,200km
 - Experiment hinges on success with this span

Timeline

- Padtec has provided LAN with specs of their Coherent technology
- LAN has provided Padtec with characteristics of its submarine system
- Simulation of the wave
 - Results estimated by end of April 2014
- Laboratory tests
 - Results estimated by end of June 2014
- Documentation Analysis and Approval
 - Completion estimated by mid August 2014
- Field Trial
 - Projected for August – November 2014

Thank You!

- OpenWave, AmLight, OSDC-PIRE, CC-NIE, AMPATH, AtlanticWave infrastructure, science application support, education, outreach and community building efforts are made possible by funding and support from:
 - National Science Foundation (NSF) awards ACI-0963053, ACI-1140833, ACI-1246185, ACI-1341895, ACI-1357928, OISE-1129076
 - FAPESP, ANSP – grant no. 2008/52885-8
 - Rede Nacional de Ensino e Pesquisa (RNP)
 - Florida International University
 - Latin American Research and Education community
 - The many national and international collaborators who support our efforts