



AtlanticWave-SDX: An International SDX to Support Science Data Applications

Jeronimo A. Bezerra and Joaquín Chung
<jbezerra@fiu.edu>, <joaquin.chung@gatech.edu>



Outline

- Introducing LSST as an Use Case
 - Presenting LSST requirements
- Software Defined Exchanges & Scientific Applications:
 - Motivation
 - Architecture
 - Applications
- Status

Introducing LSST requirements

- New scientific instruments that are being designed and deployed will increase the need for large, real-time data transfers among scientists throughout the world:
 - the Large Synoptic Survey Telescope (LSST) being built in Chile will produce 12.7 GB images that must be transmitted to the U.S. in 5 seconds;
 - at the same time, the telescope will be remotely operated from Tucson, AZ.

Introducing LSST requirements (2)

- The LSST operation will consist of two Channels:
 - Control Channel
 - Requires low latency, high priority, and low bandwidth
 - Bandwidth around a few Mbps
 - Data Channel
 - Requires high bandwidth, low latency and high priority
 - 12.7GB images to be sent in 5 seconds interval
- End-to-end path must provide high resilience, low delay, multiple paths, high bandwidth and an efficient control plane to act in all status changes

LSST: End-to-End Path

- Most of the R&E networks can accommodate some of the LSST requirements:
 - Multiple paths with multiple 100G links
 - Dynamic provisioning, bandwidth reservation, network programmability, etc.
- But R&E networks are interconnected through Academic Exchange Points:
 - Almost no support for programmability
- High demanding end-to-end applications requires that all networks in the path support QoS and Programmability
 - Including the Academic Exchange Points
- Software Defined Exchanges as a possible solution

SDX Motivation

- A Software Defined eXchange (SDX) seeks to introduce Software Defined Networking (SDN) technologies into Academic Exchange Points to optimize resource sharing and allocation
 - Inter-domain R&E network programmability
 - End-to-End QoS coordination and enforcement

SDX Architectures

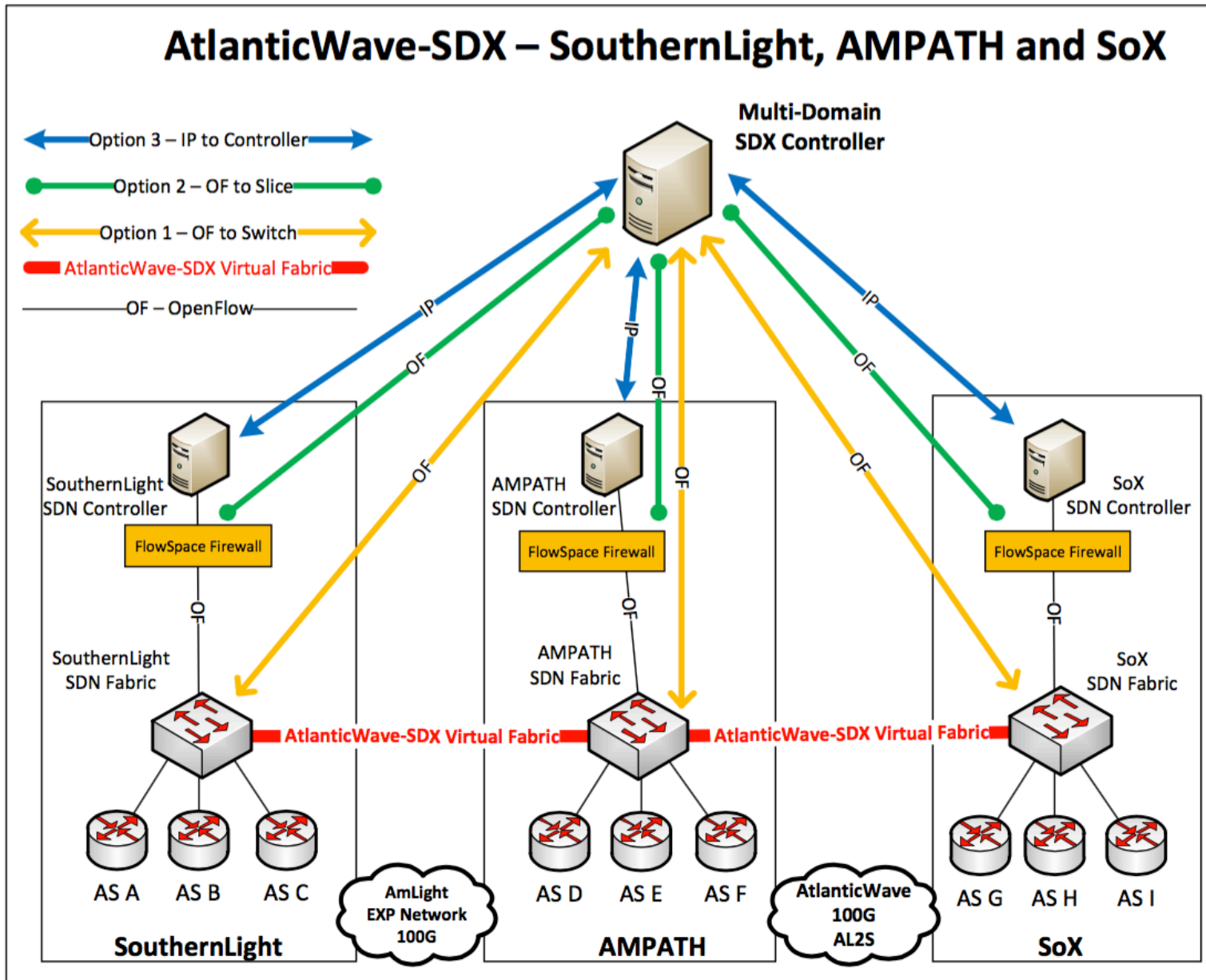

SDX Applications

- Application-specific peering
- Inbound traffic engineering
- Wide-area load balancing
- Redirection through middle boxes

SDX Policies

- Policies based on packet header field:
 - Match TCP or UDP source and destination ports,
 - Match source and destination IP address or
 - Match source and destination MAC addresses
 - Apply actions accordingly.
- Policies based on external data:
 - Collect information from other systems such as: network monitoring systems, user databases, DNS or NTP server
 - Match parameters such as network latency, bandwidth, user name, domain name, date and time
 - Apply actions accordingly.

Application Specific Peering

```
if (dstport == 80)
  forward to B
else if (dstport == 4321 || dstport == 4322)
  forward to C
```

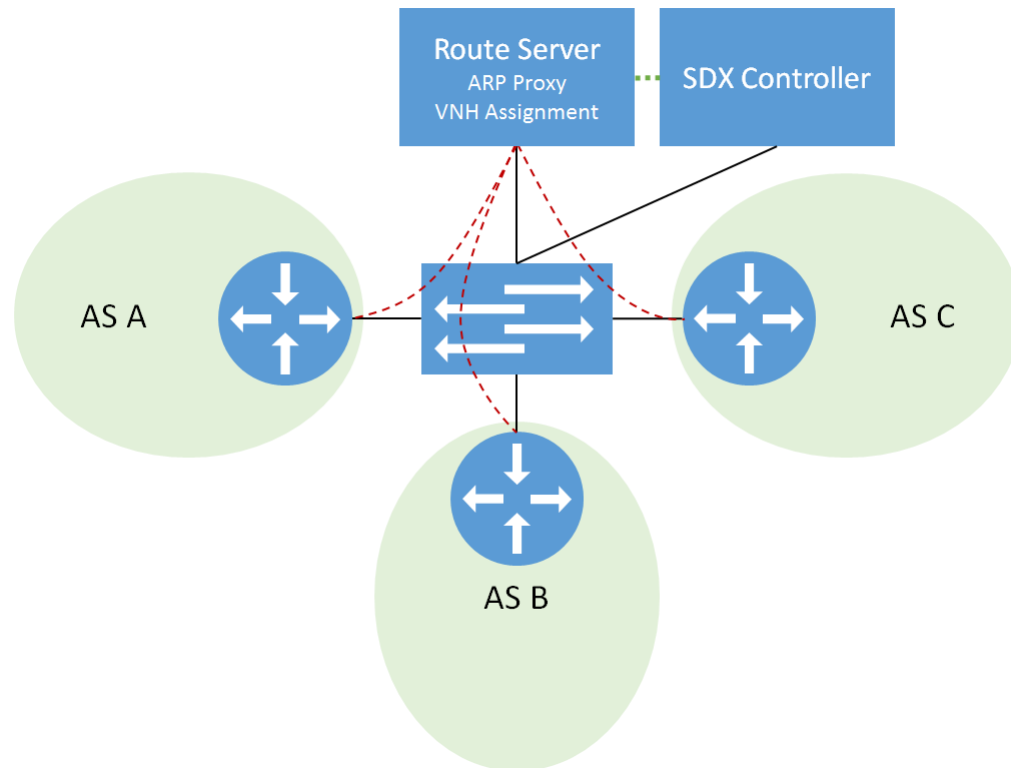

More Policy examples

- On-demand Virtual Circuit provisioning

```
if (current_latency > SLA_latency)
    secondary = findSecondaryPath()
while (current_latency > SLA_latency)
    LoadBalance(primary, secondary)
```
- Bandwidth Calendaring

```
scheduled_time = 21:00:00 GMT -5
if (current_time == scheduled_time) {
    BW = 90 // Bandwidth in Mbps
    t = 60 // Reservation time
    OnDemandVC(BW, t)
}
```

Ongoing Research

- Exploration of extended Pyretic policies
- Representation of policies as RESTful or JSON APIs
- Evaluation of new intent-based networking interfaces for SDN controllers

Status

- SDX Controller is being specified and documented:
 - Classes, interfaces and API
- A prototype is planned for the Internet2 Technology Exchange 2016 (September)
 - Possibly a demo will be presented

Conclusion

- SDX could be used to address users' requirements for compute, storage and networking resource sharing
- SDX will evolve the Academic Exchange Point
- SDX has potential to provide end-to-end inter-domain programmability and QoS
- With SDX, LSST will be able to achieve its goals of high bandwidth availability, low latency and high priority over existing R&E interconnected networks



Questions?

AtlanticWave-SDX: An International SDX to Support Science Data Applications

Joaquín Chung*, Jacob Cox*, Julio Ibarra[^], Jerônimo Bezerra[^], Heidi Morgan[^], Russell Clark*, Henry Owen*

* Georgia Institute of Technology, [^] Florida International University

* Atlanta, Georgia, [^] Miami, Florida

* {joaquin.chung, jcox70, russ.clark}@gatech.edu, [^] {julio, jbezerra, heidi}@fiu.edu, henry.owen@ece.gatech.edu

